

OPERATING INSTRUCTIONS

UHF

Professional wireless microphone system

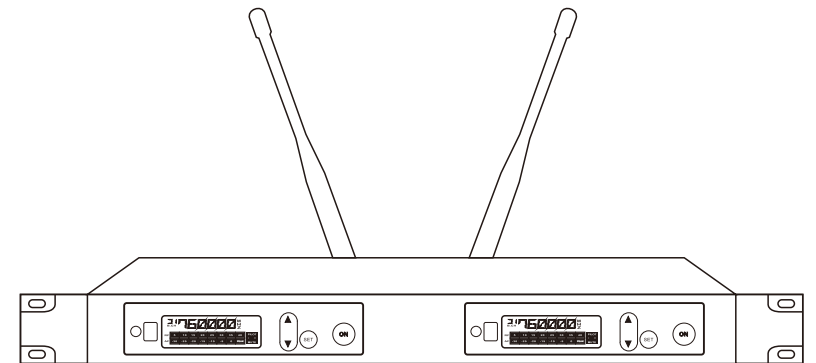

OPERATION SPECIFICATION

Professional wireless microphone system

PROFESSIONAL AUDIO WORKS

<p>CAUTION RISK OF ELECTRIC SHOCK DO NOT OPEN</p>	<p>AVIS RISQUE DE CHOC ELECTRIQUE N'OUVREZ PAS</p>
<p>TO PREVENT ELECTRIC SHOCK DO NOT REMOVE TOP OR BOTTOM COVERS. NO USER SERVICEABLE PARTS INSIDE. REFER SERVICING TO QUALIFIED SERVICE PERSONNEL. DISCONNECT POWER CORD BEFORE REMOVING REAR INPUT MODULE TO ACCESS GAIN SWITCH.</p>	<p>A PREVENIR LE CHOC ELECTRIQUE N'ENLEVEZ PAS LES COUVERTURES. RIEN DES PARTIES UTILES A L'INTERIEUR. DEBRANCHER LA BORNE AVANT D'OUVRIR LA MODULE EN ARRIERE</p>



WARNING

TO REDUCE THE RISK OF ELECTRIC SHOCK, DO NOT EXPOSE THIS EQUIPMENT TO RAIN OR MOISTURE!

Magnetic Field

CAUTION! Do not locate sensitive high-gain equipment such as preamplifiers or tape decks directly above or below the unit. Because this amplifier has a high power density. It has a strong magnetic field which can induce hum into unshielded devices that are located nearby. The field is strongest just above and below the unit.

If an equipment rack is used, we recommend locating the amplifier(s) in the bottom of the rack and the preamplifier or other sensitive equipment at the top.

WATCH FOR THESE SYMBOLS:



The lightning bolt triangle is used to alert the user to the risks of electric shock



The exclamation point triangle is used to alert the user to important operating or maintenance instructions.



Printed on recycled paper

Specifications

System specifications	
Modulation Mode	Wideband FM
Frequency Range	740-790MHZ
Channel number	200 channel preset
Frequency stability	±0.005%
Dynamic range	100dB
Maximum deviation	±48KHZ
Audio frequency response	40HZ-18KHZ(±3dB)
Signal-to-noise ratio	105dB
Distortion	≤0.3%
Adjacent channel inhibition	≥70dB
Working distance	about 100 meter
Receiver specification	
Receive mode	receive automatic choose
Oscillation way	PLL Synthesized
Antenna input	BNC socket/(50 Ω)
Cascade output	BNC socket/(50 Ω), Gain: 0dBm±2dB
Middle Frequency	110 MHz、10.7MHZ
Sensitivity	12 dBuV (80dBBS/N)
Spurious Signals	≥75dB
Maximum output level	+10dBV
Power supply	12V DC
working current	≤500mA
transmitters specification	
Antenna	Hand-held microphone built-in spiral antenna, body pack by a quarter wave transmitter prehensile bullwhip shaped antenna
Rf output power	High power: 30mW, Low power: 3mW
Sound pickup head	Moving coil type
Spurious Signals	-60dB
Power Supply	Two AA alkaline batteries no. 5
Operating time	High power:6 hours; Low power: 10 hours
Overall unit	
Work environment temperature	-10°C+40°C

Troubleshooting

Some common problems and their solutions are identified in the table below. If you are unable to solve a problem, contact your dealer.

Problem	
No sound; Channel not glowing.	<ul style="list-style-type: none"> • Make sure the transmitter and receiver POWER switches are ON. • Check battery. • Check receiver squelch setting. • Check receiver antenna connection(s). • Make sure antennas are in line of sight of transmitter.
No sound; Indicator and Audio Level meter lights glowing.	<ul style="list-style-type: none"> • Turn up receiver audio VOLUME control. • Check for proper connection between receiver and karaoke unit. • Talk into microphone and observe receiver audio level lights. If they glow, the problem is elsewhere in the sound system.
Received signal is noisy or contains extraneous sounds with transmitter on.	<ul style="list-style-type: none"> • Check battery. • Remove local sources of RF interference. • If using a guitar or other instrument, check connections. • Two transmitters may be operating on the same frequency. Locate and turn one off. • Signal may be too weak. Reposition antennas. If possible, move them closer to transmitter.
Noise from receiver with transmitter off.	<ul style="list-style-type: none"> • Adjust receiver squelch control. • Remove local sources RF interference. • Reposition receiver or antennas.
Momentary loss of sound as transmitter is moved around performing area.	<ul style="list-style-type: none"> • Reposition receiver and perform another walkthrough test and observe the RF indicators. If audio dropouts persist, mark these dead spots in performing area and avoid them during performance.

Preface	1
Receiver Accessories	2
Switch ON/OFF steps	3
Receiver operation guide	4
Handset microphone emitter parts	6
Handset switch on/switch off	7
Battery installation	8
Body pack / lavalier transmitter parts	9
Troubleshooting	11
Specifications	12

PREFACE

Thanks for purchasing this product. Please read this instruction carefully before using the system so that you can make sure in detail by the numbers how to install, operate and safeguard the system.

Our special wireless microphone system has characteristics as the following. For many reasons, such as low frequency, traditional wireless microphone system are easy to be interfered, especially because many machines, CD, VCD and LD, eradicate out too many harmonic. To solve this problem. We design this kind true diversity professional wireless microphone. We adopt a series of measures to improve its functions, advance frequency, using multilevel high frequency and mid frequency narrowband filter, multiple noise detect and control. We also design it special functions (tone keylicked identity) to avoid interference from outside.

LCD interface

Body pack / lavalier transmitter operations.

Batter installation as below:

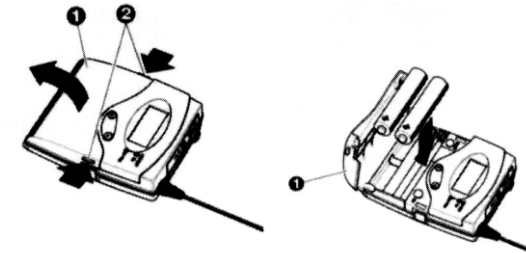

1. Press two buttons to unlock (Picture 2), and open battery hatch (Picture 1).
2. Please note, put two batteries in the correct polarity to the battery hatch. (as left picture).
3. Close the battery hatch, the battery hatch in place a snickering lock sound.

Accessories List

	Description	Unit	Qty
1	Adapter	PCS	1
2	Antenna	PCS	2
3	Angle yards cwith	SET	1
4	6.35Audio connection line	PCS	1
5	Manual	PCS	1

Body pack / lavalier transmitter parts:

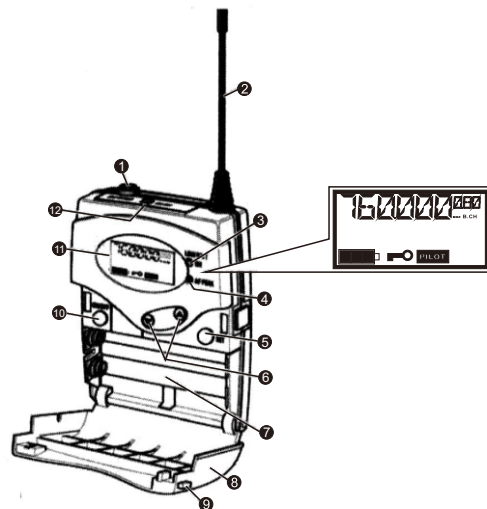

1. Headset line / lavalier line input
2. Whip shape antenna
3. Low battery: The battery status, low power instructions when flashing.
4. PEAK: It will light when sound too big.
5. Press SET key can cycle, choose manu press or to the manu of the currently selected key state change, then press SET key setting to take effect.
6. Upward or Downward.
7. Battery hatch.
8. Battery cover.
9. Button to open the cover.
10. Power switch ON / OFF long press 2 seconds to open, long press 2 seconds off.
11. LCD
12. MUTE: Mute switch.

Receiver Accessories

1. Front panel.

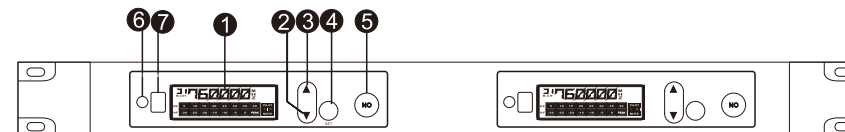

1. LCD It can display channel ,mute, receive signal level.
2. Upward
3. Down
4. SET functions switch, press this button can cycle options menu press upward switch or down switch, of menu currently selected state change, Then press SET key setting to take effect.
5. Power ON/OFF switch.
6. Infrared automatic switch.
7. Infrared window, cooperation of infrared button, Will send channel data transfer to transmitters.

2. Back panel

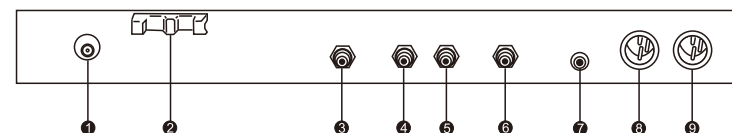

1. Power supply socket, 12VDC input voltage.
2. The power cord clasp, fasten the power cord. To avoid electrical outlet accident cause use interrupt.
3. BNC socket, antenna input.
4. BNC socket, cascade output; As a machine. or ther connection link antenna booster used.
7. ϕ 6.3 audio Mixing output outlet. Let left and right mixed signal output together.
8. XLR balanced output outlet. Let left and right signal output alone.

3. Receiver Lcd display

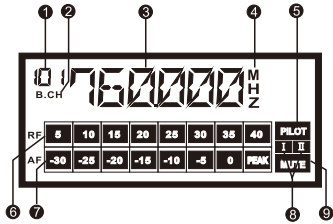

- 1.Channel Indicator: Show the current use of the channel.
- 2.B. Ch is Channel abbreviations.
- 3.Frequency Indicator: Show the current use of the frequency.
- 4.MHZ is frequency unit.
- 5.PILOT Indicator.
- 6.8 class rf level shows, display received RF signal strength.
- 7.Diversity display: automatic display the current use the antenna I or II.
- 9.Mute display: It means the receiver is not receive RF signal

Switch ON/OFF steps

1.Connection method.

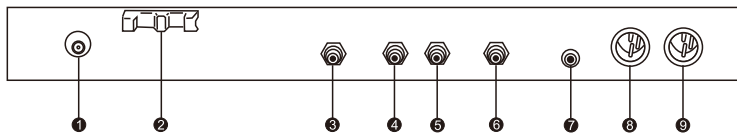

- 1.Put the receiver placed in power amplifier or Mixer system, connect to the power supply. (link to position (1),winding in position (2))
- 2.Connect one side of audio. Line to this machine' s mixing audio out put, Connect another side of. audio line to power amplifier or mixer' s microphone input.
- 3.Connect two balanced audio line. To the balanced output socket if need output independently, that is double channel Output independently (link to position.(8)(9))
- 4.Connect the antenna. Into indenpendently. The left and right sides of the antenna seats. (link to(3)(6)) .

1.Battery installation.

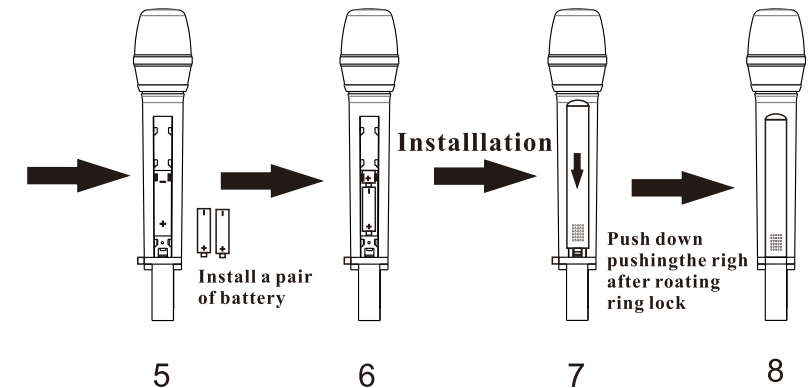
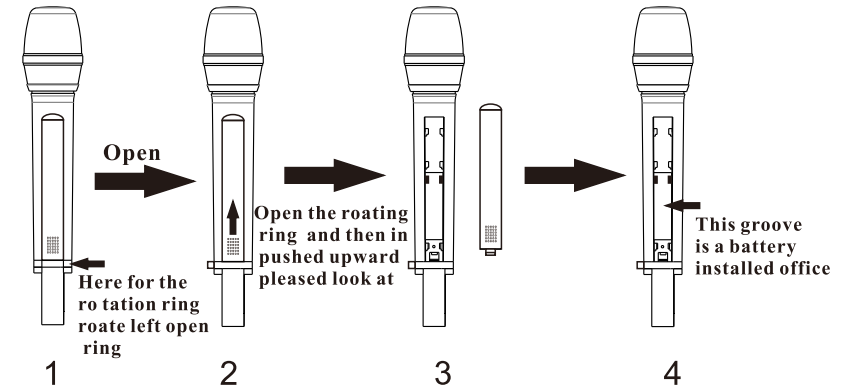

- 1.Grille (including microphone core).
- 2.Metal tube body: Inside with a battery, launch, launch circuit boards, tail built-in antenna.
- 3.LCD: display frequency, channel the battery power.
- 4.Battery switch: Up to boot state, down for shutdown state.
- 5.Infrared frequency window: With the receiver to the frequency of key, the data transmission channel to transmitters.

Handset switch on/switch off

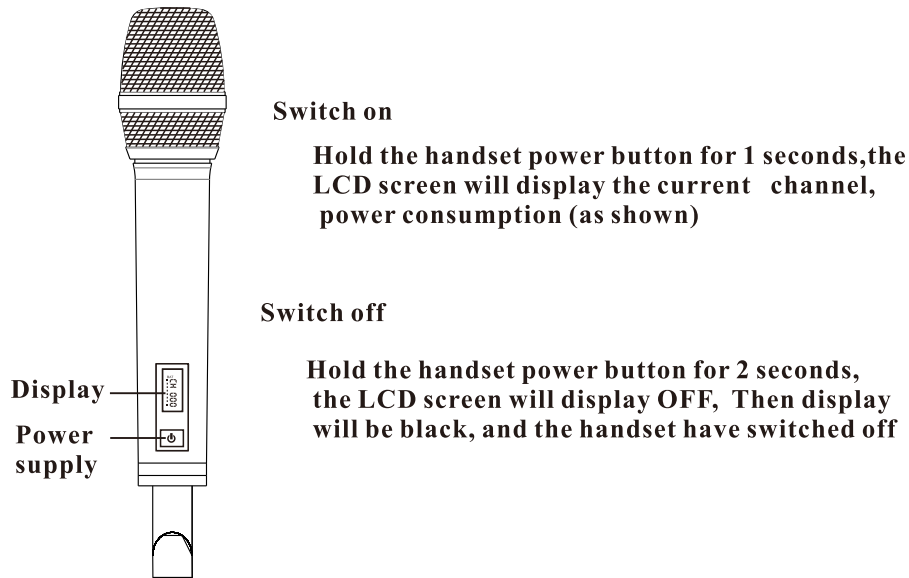

2、 Switch ON

- 1.Confirm connection is correct, adjust power amplifier or mixer' s volume to minimum and press "ON" , then the display is lighting, and green turn to red colour "MUTE" display, the receiver is standby mode.
- 2.Open the emitter, and put the battery in.

3.Switch OFF.

Please adjust amplifier and mixer' s volume to minimum, be for switch off, press "ON" button 3 seconds, then turn off. Please take off battery.

Receiver operation guide

1.Channel setting

When need to adjust the frequency, Press the SET key into the frequency adjustment interface, Now LCD is flashing , press setting to frequency required. And press SET key to confirm. Stop and return to the main menu at this time setting to take effect.

2.Frequency setting

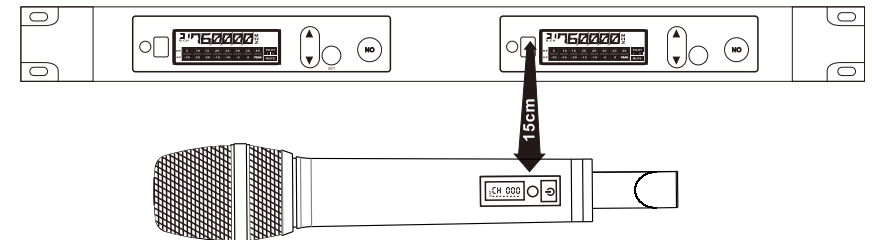

Set the frequency required after the infrared transmitter' s infrared to the window of the infrared receiver launch window; A distance of about 15 centimeters, press the key of frequency. At this time; the launch window infrared receiver will see the lights flashing. Said the frequency data are transmitted receiver when the transmitter' s .LED is on ; says this time is received and transmitted frequency synchronization, the setting is taken effect.

3. Volume adjustment



Press ▼ ▲ key into volume adjustment interface without press SET key (such as above) display the current volume and flashing (Minimum 0, Maximum 30, factory set to 20), according to the required volume, press “SET” key to confirm flashing stop and return to the main menu. Now the setting is taken effect.

4. Sensitivity adjustment

Continuous press SET key two times, Right now display the current sensitivity, and flash interface. To adjust ▼ ▲ key required state (Factory set to SQ HI), The press SET key confirmation. Stop flashing and return to the main menu, Now the setting is taken effect.



- HI-high distance receive.
- MID-middle distance receive.
- LOW-Low close range receive.

Note: This function to meet different environmental radio interference use environment and design. General without setting so as not to affect the receiving distance and affect use effect.

5. System lock

1. Locking

In order to prevent the use process wrongly operation and change the original set parameters, the design of the receiver as mobile phone locks the interface lock function use more reliable.

Continuous press SET key three times locking state at this time. Interface flashing press ▼ to display the pictures as below. Then press SET key confirmation Flashing stop and return to the main menu. Now take effect.



2. Unlock

When press SET key, the following figure display appear, said the current system is locked state. Now only the volume adjustment and function of frequency is available.



Long press SET key three seconds to unlock that state. Now appear as follow figure interface and flashing.



Press key to change state. As below, Then press SET key confirmation stop flashing and return to the main menu. Now unlock setting to take effect.



Note: The above functions in the operation, to change the original parameter setting in has not press SET key, the system will be confirmed in action without buttons 10 seconds to be automatic and go back to the main menu.

Handset microphone emitter parts

